

DRAWING NUMBER		4
TOLERANCE FOR METAL		
DIVISION	TOLERANCE	
-3	±0.05	
3-6	±0.05	
6-30	±0.10	
30-120	±0.15	
120-400	±0.20	
400-1000	±0.30	
1000-2000	±0.50	

REVISIONS				
REV	ZONE	DESCRIPTION	ECR	CHECKED

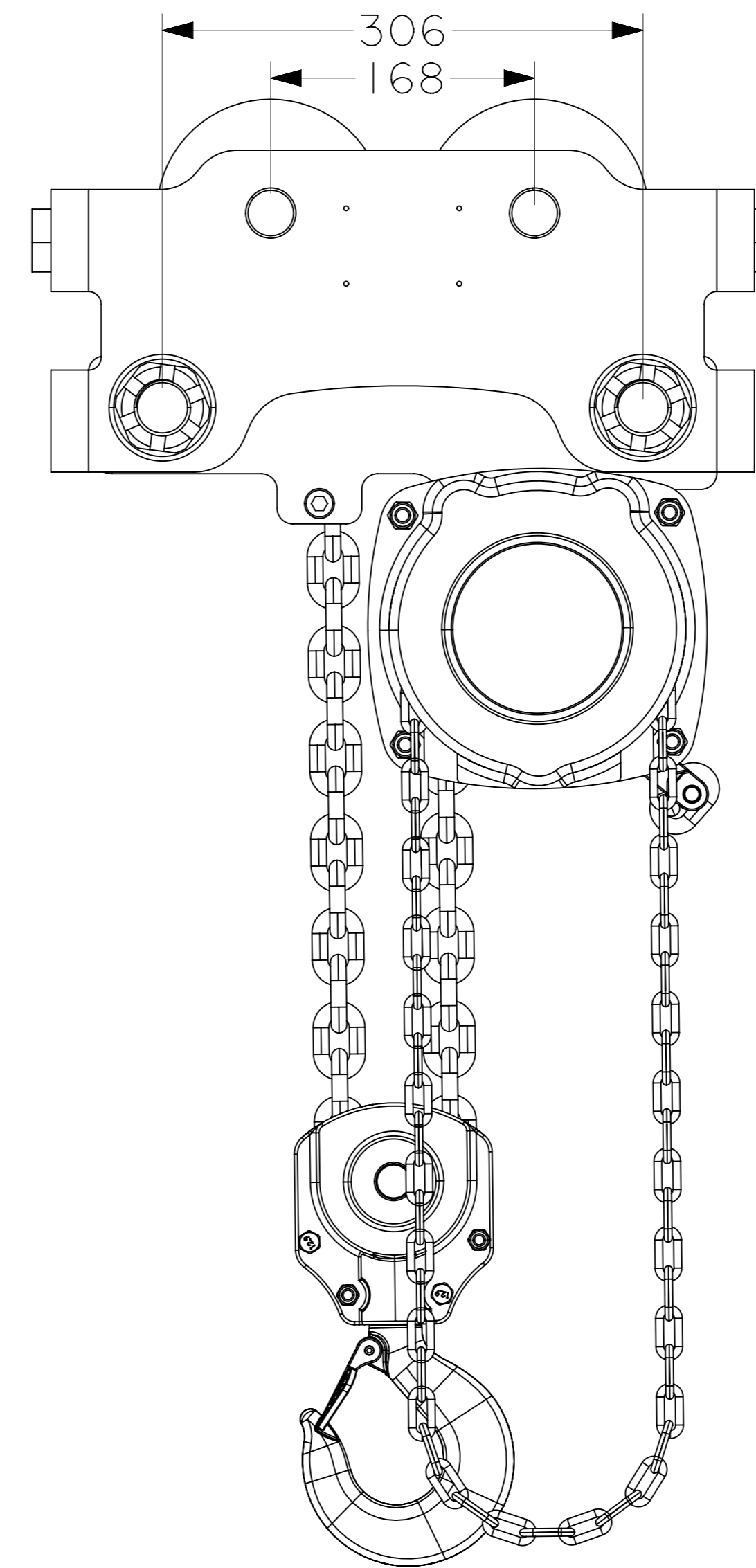

- NOTES
1. LHT-H-050L, RATED CAPACITY 5.0T.
 2. FLANGE WIDTH 114-203mm, MAX. FLANGE WIDTH 305 CAN BE MADE.
 3. HAND CHAIN SPEC. 5X25mm. THE MIN HEADROOM 568mm.
 4. SHAFT DIA.=39mm, THK15mm SLEEVE 8PCS, THK3mm SLEEVE 24PCS.

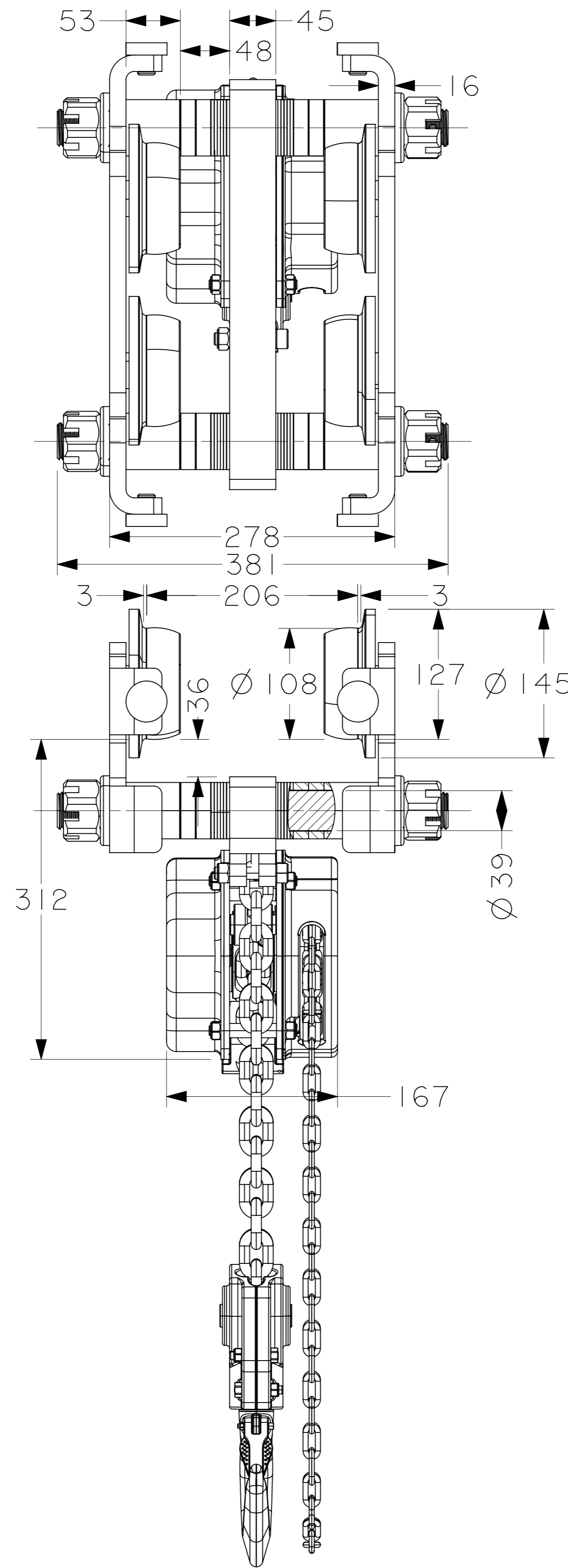
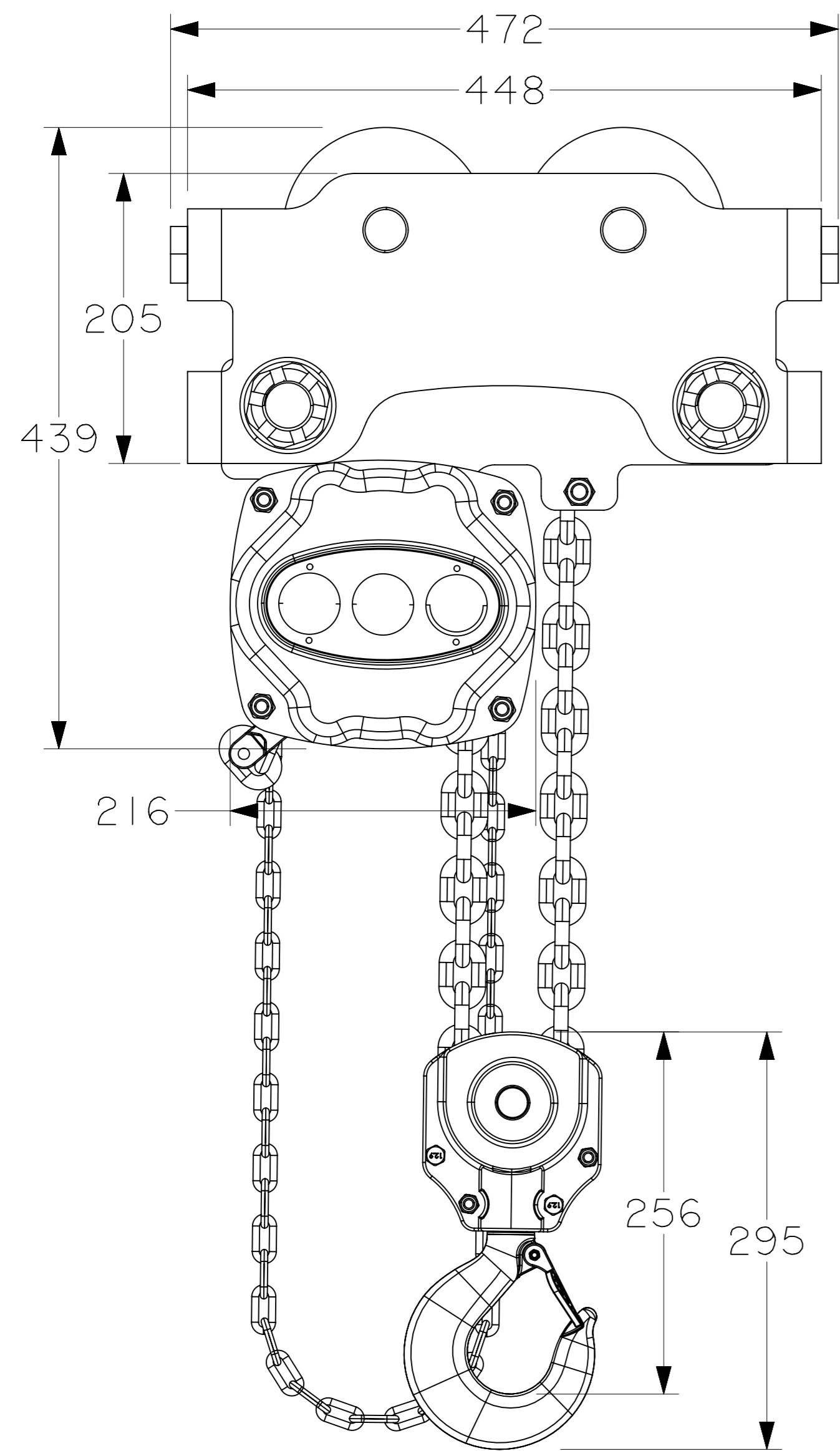
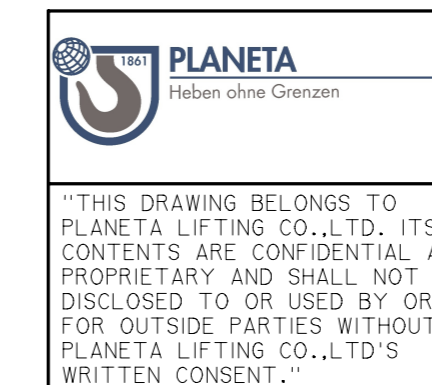

UNLESS OTHERWISE SPECIFIED DIMENSIONS ARE IN MILLIMETERS. FOR ALL UNSPECIFIED DIMENSIONS PLEASE REFER TO THE CAD FILE. DO NOT SCALE. USE DIMENSIONS ONLY. DIMENSION & TOLERANCE PER DIN ISO 2768-F	DRAWN BY JACKY 19/11/29	DATE	PLANETA LIFTING CO.,LTD
FIRST ANGLE PROJECTION	CHECKED BY	DATE	TITLE LHT-H-050L 5.0T
	APPROVED BY	DATE	
	MATERIAL NA	SCALE NA	SIZE 4
			DRAWING NUMBER 01
			REV 01
			SHEET OF 1