

DRAWING NUMBER		4
TOLERANCE FOR METAL		
DIVISION	DIMENSION	TOLERANCE
-3		±0.05
3-6		±0.05
6-30		±0.10
30-120		±0.15
120-400		±0.20
400-1000		±0.30
1000-2000		±0.50

REVISIONS				
REV	ZONE	DESCRIPTION	ECR	CHECKED

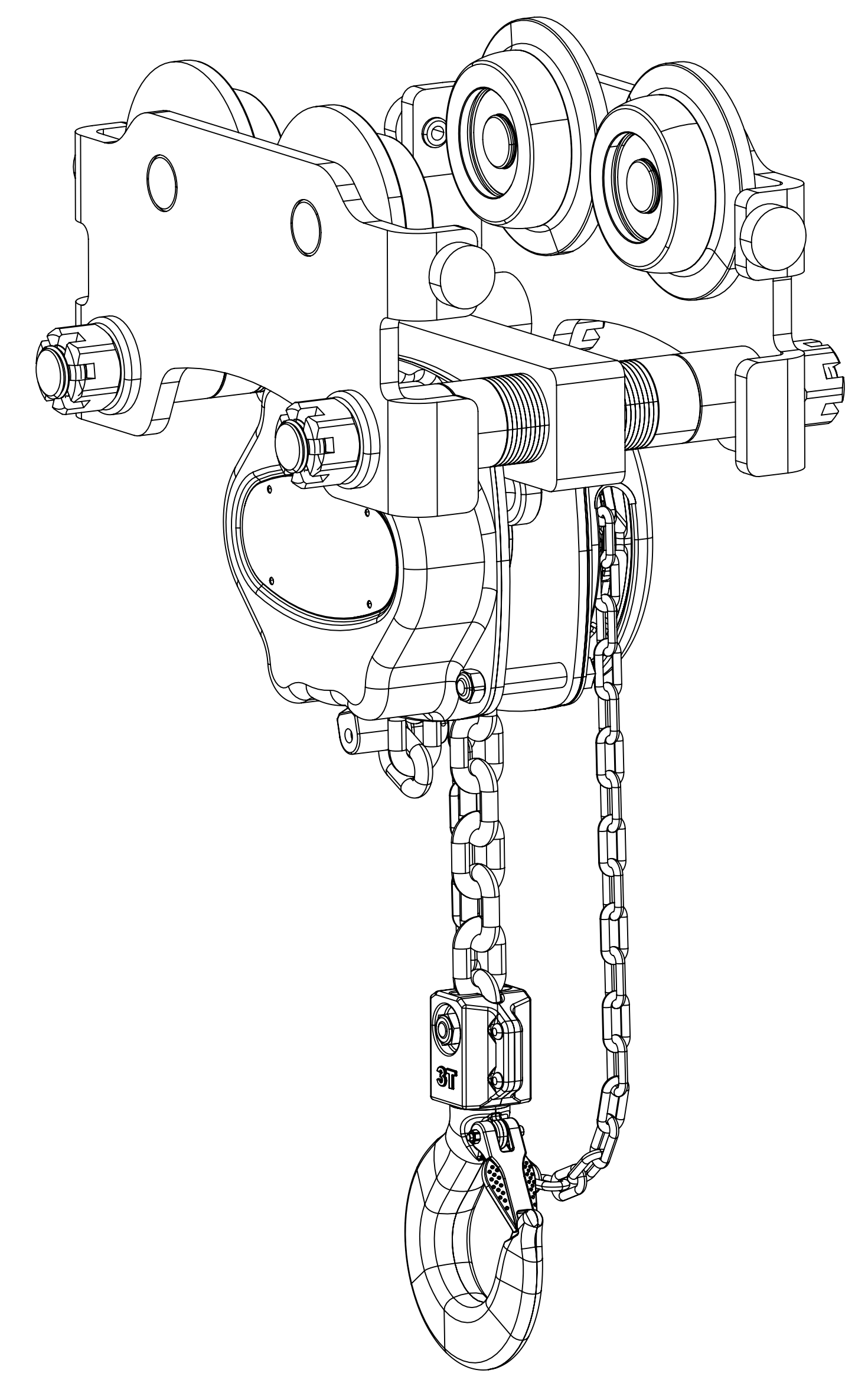
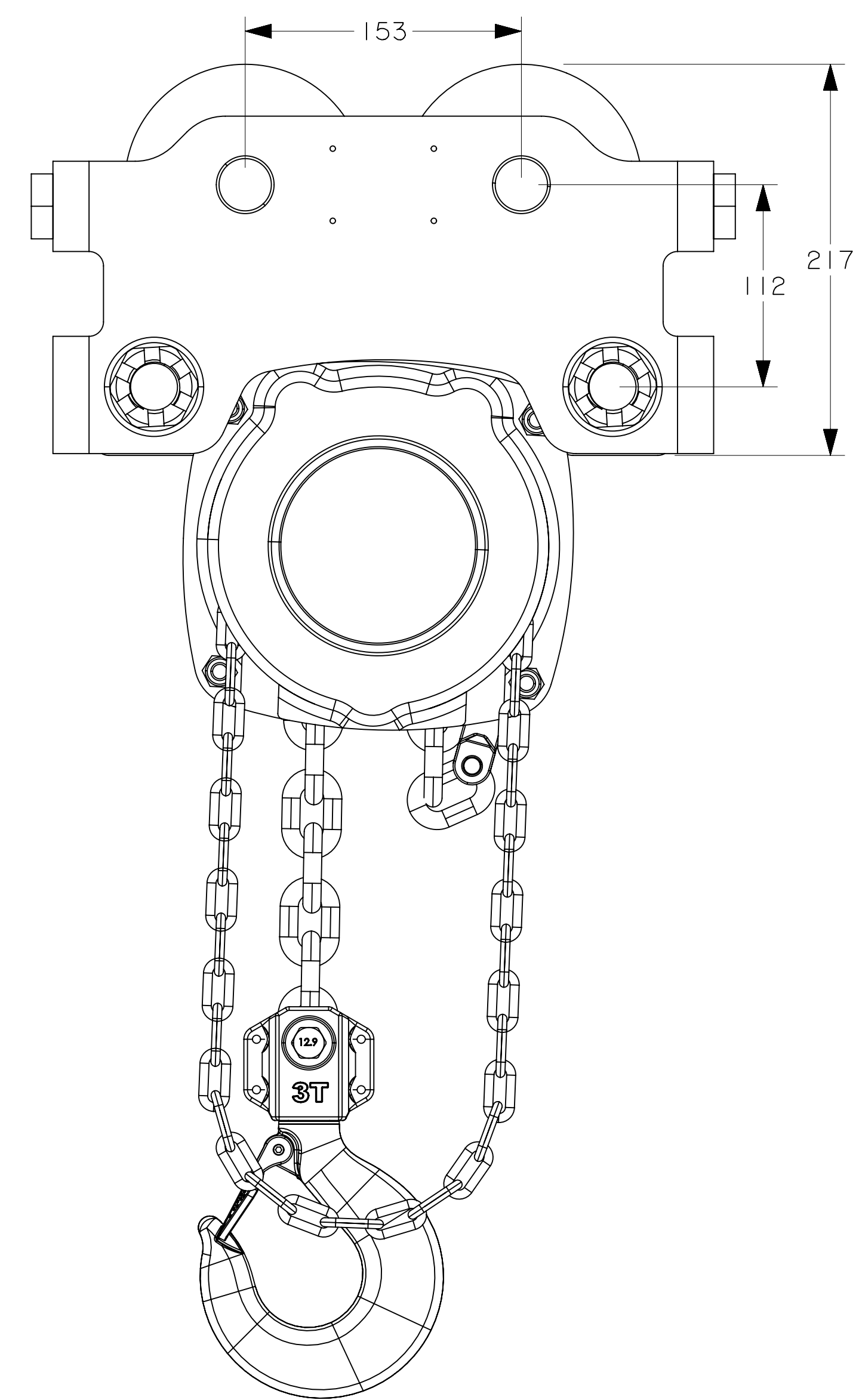
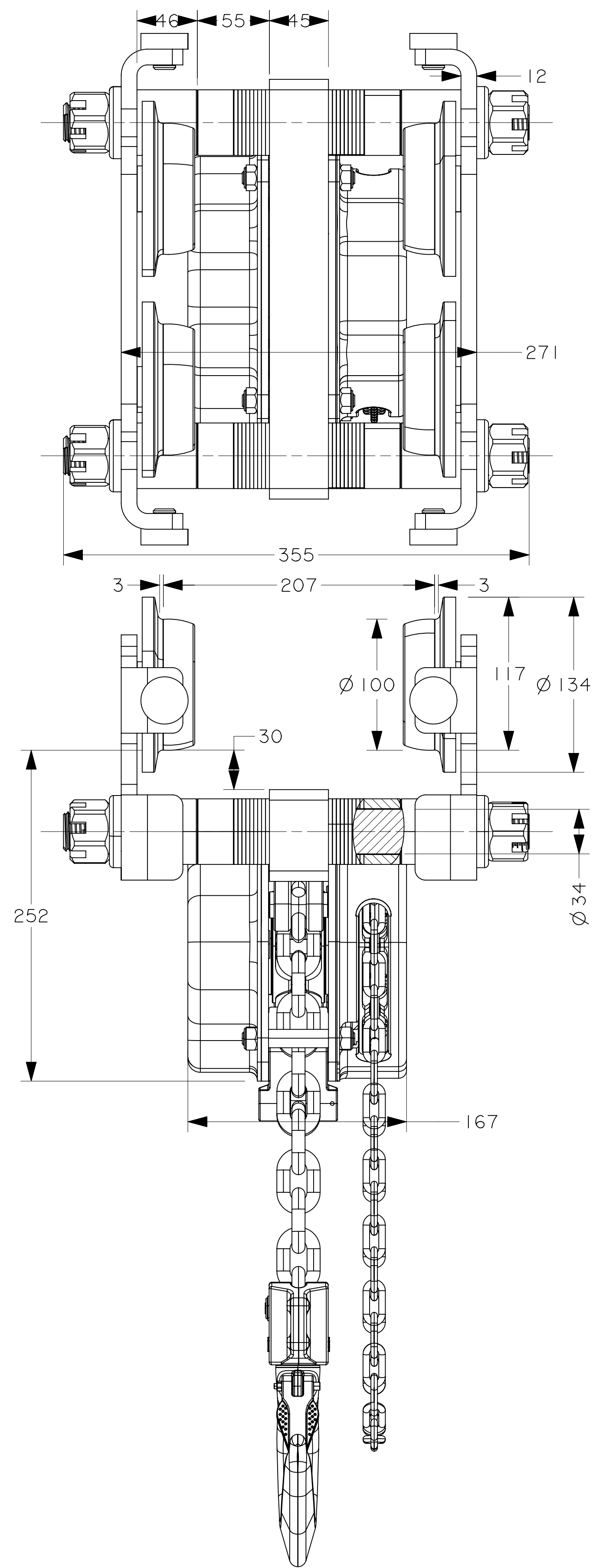
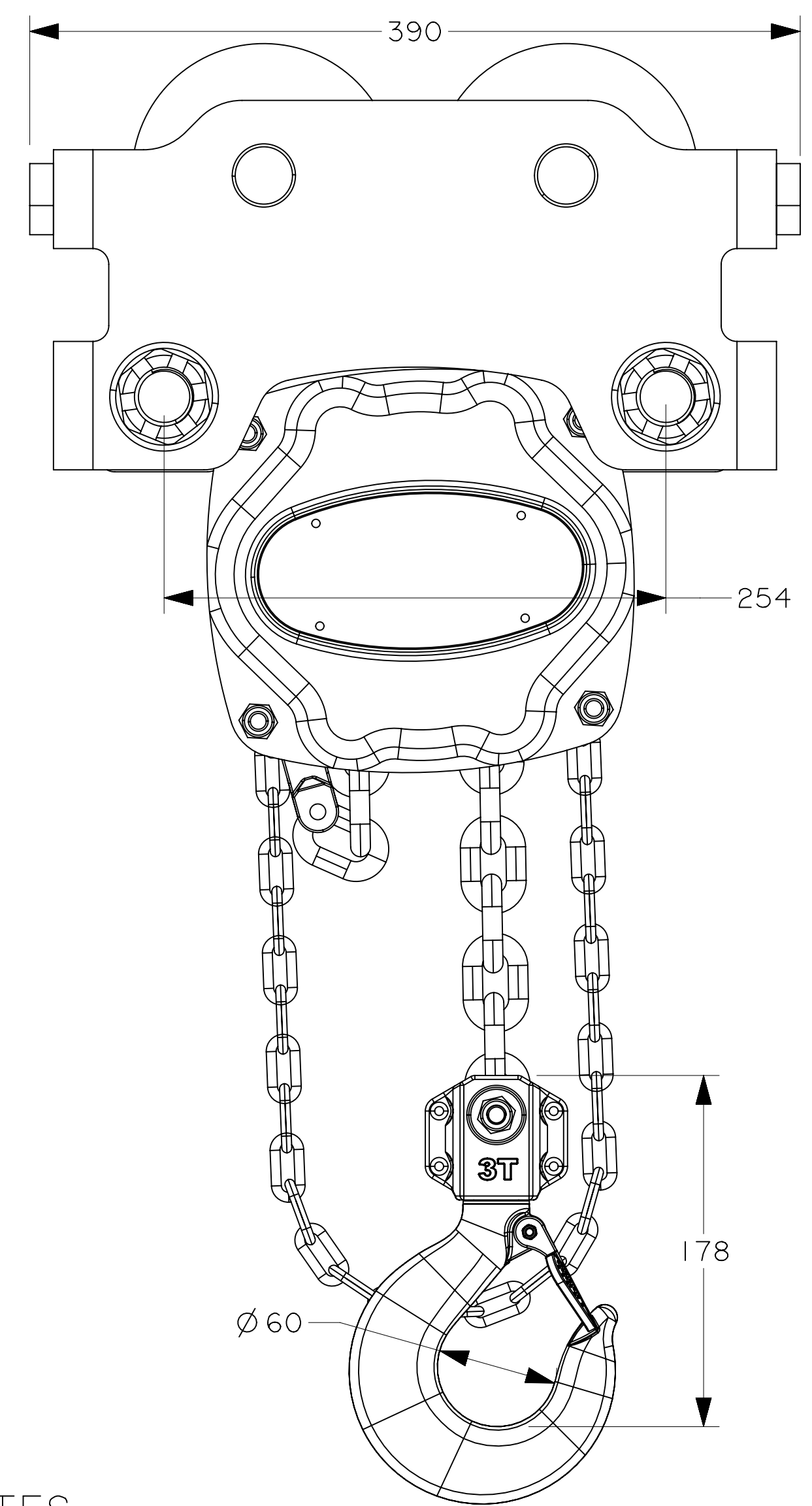

- NOTES
1. LHT-H-030L, RATED CAPACITY 3.0T.
 2. FLANGE WIDTH 100-203mm, MAX. FLANGE WIDTH 305 CAN BE MADE.
 3. HAND CHAIN SPEC. 5X25mm. THE MIN HEADROOM 430mm.
 4. SHAFT DIA.=34mm, THK28mm SLEEVE 4PCS, THK3mm SLEEVE 36PCS.

	UNLESS OTHERWISE SPECIFIED DIMENSIONS ARE IN MILLIMETERS. FOR ALL UNSPECIFIED DIMENSIONS PLEASE REFER TO THE CAD FILE. DO NOT SCALE. USE DIMENSIONS ONLY. DIMENSION & TOLERANCE PER DIN ISO 2768-F	DRAWN BY JACKY	DATE 19/11/29	PLANETA LIFTING CO.,LTD	
		CHECKED BY	DATE	TITLE LHT-H-030L 3.0T	
		APPROVED BY	DATE		
		MATERIAL NA		SIZE 4	DRAWING NUMBER 01
	FIRST ANGLE PROJECTION			SCALE NA	SHEET OF 1